

- personal protective equipment must be withdrawn from use immediately when any doubt arise about its condition for safe use and not used again until confirmed in writing by equipment manufacturer or his representative after carried out the detailed inspection.
- personal protective equipment must be withdrawn from use immediately and destroyed when it have been used to arrest a fall.
- a full body harness is the only acceptable body holding device that can be used in a fall arrest system.
- in full body harness use only attaching points marked with big letter "A" to attach a fall arrest system. Marking like "A/2" or a half of "A" means the necessity of attaching a fall arrest system to both attaching points together simultaneously. It is strictly forbidden to attach a fall arrest system to the single attaching point marked "A/2" or a half of "A". See drawings below:

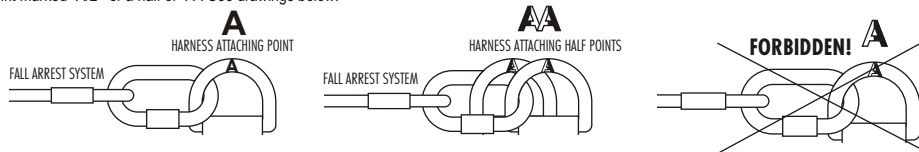

- the anchor device or anchor point for the fall arrest system should always be positioned, and the work carried out in such a way, as to minimise both the potential for falls and potential fall distance. The anchor device/point should be placed above the position of the user. The shape and construction of the anchor device/point shall not allowed to self-acting disconnection of the equipment. Minimal static strength of the anchor device/point is 15 kN. It is recommended to use certified and marked structural anchor point complied with EN795.
- it is obligatory to verify the free space required beneath the user at the workplace before each occasion of use the fall arrest system, so that, in the case of a fall, there will be no collision with the ground or other obstacle in the fall path. The required value of the free space should be taken from instruction manual of used equipment.
- there are many hazards that may affect the performance of the equipment and corresponding safety precautions that have to be observed during equipment utilization, especially:
 - trailing or looping of lanyards or lifelines over sharp edges;
 - pendulum falls;
 - any defects like cutting, abrasion, corrosion;
 - extremes of temperature;
 - chemical reagents;
 - climatic exposure;
 - electrical conductivity.
- personal protective equipment must be transported in the package (e.g.: bag made of moisture-proof textile or foil bag or cases made of steel or plastic) to protect it against damage or moisture.
- the equipment can be cleaned without causing adverse effect on the materials in the manufacture of the equipment. For textile products use mild detergents for delicate fabrics, wash by hand or in a machine and rinse in water. Plastic parts can be cleaned only with water. When the equipment becomes wet, either from being in use or when due cleaning, it shall be allowed to dry naturally, and shall be kept away from direct heat. In metallic products some mechanic parts (spring, pin, hinge, etc.) can be regularly slightly lubricated to ensure better operation. Other maintenance and cleaning procedures should be adhered to detailed instructions stated in the manual of the equipment.
- personal protective equipment should be stored loosely packed, in a well-ventilated place, protected from direct light, ultraviolet degradation, damp environment, sharp edges, extreme temperatures and corrosive or aggressive substances.

TIME OF USE

The rope grab can be used for 5 years counting from a date of putting it into operation. After this period the rope grab must be withdrawn from use to carry out detailed manufacturer's inspection.

The inspection can be carried out by:

- manufacturer
- or person recommended by the manufacturer
- or company recommended by manufacturer.

During this inspection will be established admissible time of use of the rope grab till next fabric control.

Working rope must be withdrawn from use and destroyed after 5 years of use.

Whole fall arrester including rope grab, working rope and connectors must be withdrawn from use immediately and destroyed when it have been used to arrest a fall.

MARKING

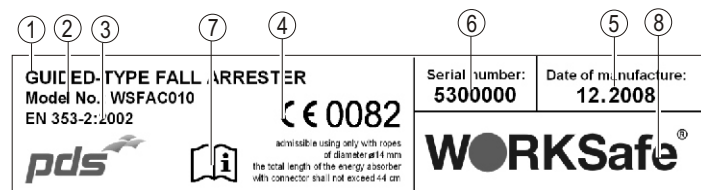

- name (type) of the device.
- reference number
- European standard (number/year).
- CE marking and number of a notified body controlling manufacturing of the equipment (art. 11).
- month/year of manufacture.
- number of manufacturing serie.
- caution: read the manual
- marking of device manufacturer of distributor.
- material of which the device is made of.
- diameter of the rope.
- length of the rope.

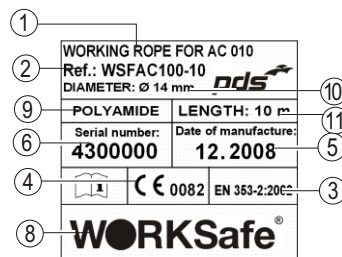

Instruction Manual

READ CAREFULLY BEFORE USE
THE EQUIPMENT

CE 0082 EN 353-2:2002

WORKSafe[®]
GUIDED-TYPE FALL ARRESTER
ON FLEXIBLE ANCHORAGE LINE
WSFAC010

WSFAC010 is a guided-type fall arrester device on flexible anchorage guide.

The rope grab is sliding on Ø14 mm polyamide rope.

WSFAC010 is a component of personal protective equipment against falls from a height.

WSFAC010 guided-type fall arrester complies with EN 353-2.

BASIC EQUIPMENT

- rope grab with energy dissipating element. Energy dissipating element can be equipped only with certified (according EN 362) connector (snap hook). The total length of the dissipating element (energy absorber) with connector shall not exceed 44 cm.
- working rope (Ø14 mm kernmantle polyamide). The rope is ended with sewn loops equipped with thimbles.

ATTENTION: the total length of the dissipating element (energy absorber) with connector shall not exceed 44 cm.

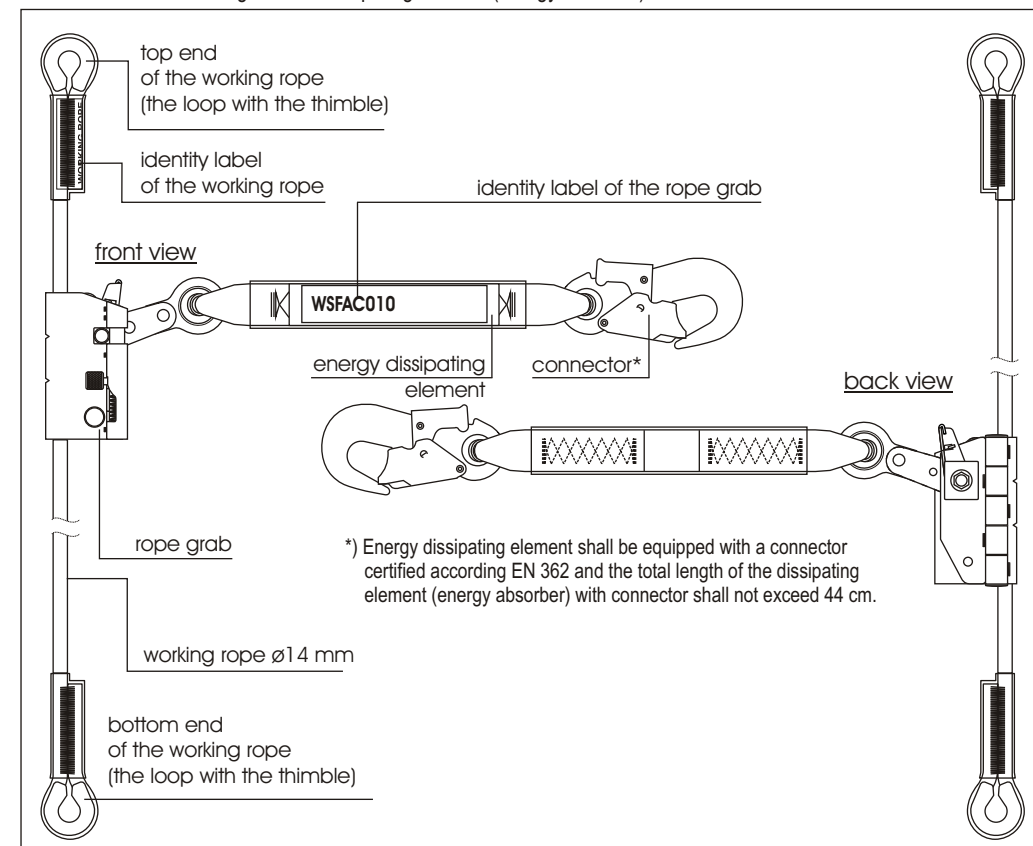

*) Energy dissipating element shall be equipped with a connector certified according EN 362 and the total length of the dissipating element (energy absorber) with connector shall not exceed 44 cm.

Using the WSFAC010 fall arrester in connection with fall arrest system must be compatible with use instructions of the fall arrest systems and obligatory standards:

- EN361 - for the safety harness;
- EN353-2, EN354, EN362 - for the fall arrest systems;
- EN 795 - for anchorages
- EN358 - for the work positioning systems.

CONNECTING WSFAC010 ROPE GRAB TO THE SAFETY HARNESS

- AC 010 rope grab must be connected to front or back attaching point of full body harness. The full body harness must comply with EN361 **1**
- it is strictly forbidden to connect WSFAC010 rope grab to the work positioning belt **2**
- it is strictly forbidden to add any additional element between rope grab's snap hook and attaching point of the harness **3**

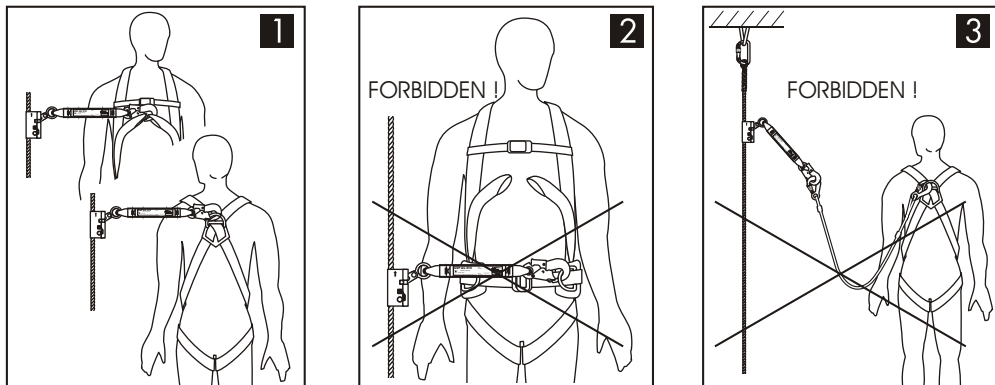

CONNECTING THE WORKING ROPE TO THE STRUCTURAL ANCHOR POINT

Attention!
Structural anchor point should have static resistance min. 15 kN.
The shape of the structural anchor point should not let self-acting disconnection of the rope

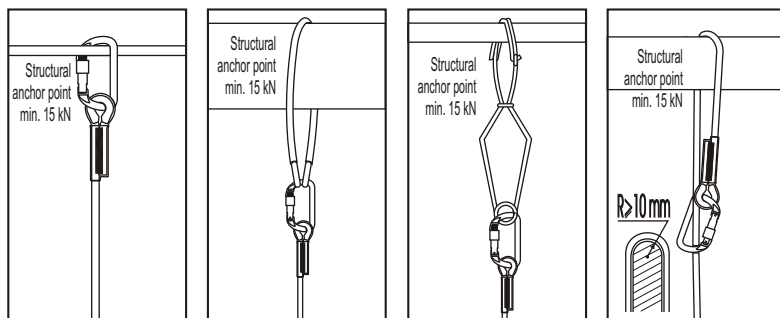

INSTALLING THE ROPE GRAB ON THE WORKING ROPE

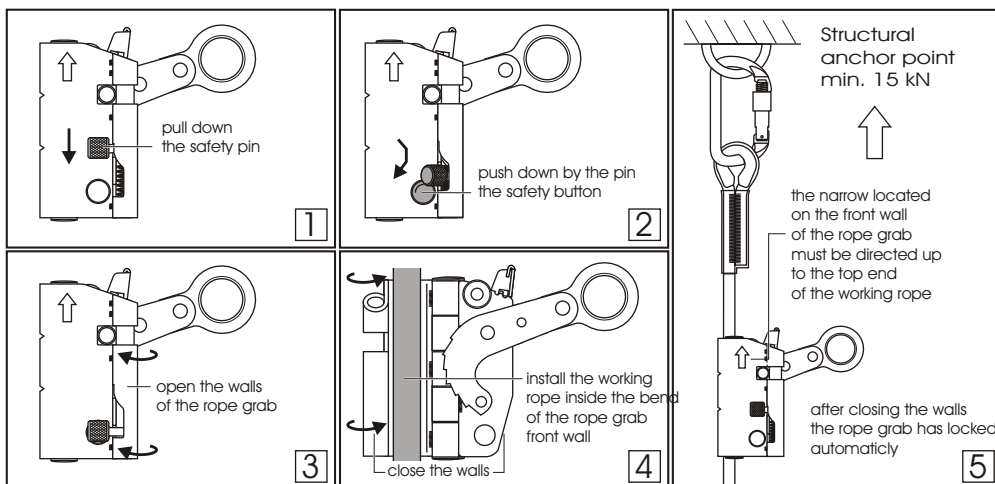

REQUIRED FREE DISTANCE BELOW WORKING LEVEL

- structural anchor point to which will be connected working rope should be situated above working position and should have static resistance min. 15kN. Free distance below the working surface depends on the length of the working rope under the worker - see the table and drawing A:

Length of the rope over the worker [m] - L	10	20	30	40	50
Free distance below the working surface [m] - X	3,2	4,60	6,00	7,40	8,80

- during horizontal moving of the worker, the working rope deflection from the vertical line up to 45° is allowed - see the drawing B.

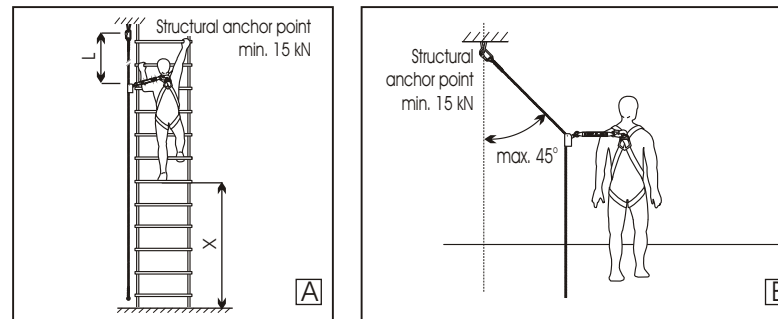

WORKING IN ONE STAND

- during the work in one stand the rope grab should be moved (by hand) under the line of the connecting buckle of the harness and blocked on the working rope. Stopped in one place rope grab is not disturbing the worker. See the drawings below:

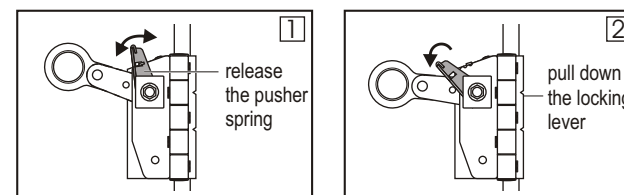

THE ESSENTIAL PRINCIPLES FOR USERS OF PERSONAL PROTECTIVE EQUIPMENT AGAINST FALLS FROM A HEIGHT

- personal protective equipment shall only be used by a person trained and competent in its safe use.
- personal protective equipment must not be used by a person with medical condition that could affect the safety of the equipment user in normal and emergency use.
- a rescue plan shall be in place to deal with any emergencies that could arise during the work.
- it is forbidden to make any alterations or additions to the equipment without the manufacturer's prior written consent.
- any repair shall only be carried out by equipment manufacturer or his certified representative.
- personal protective equipment shall not be used outside its limitations, or for any purpose other than that for which it is intended.
- personal protective equipment should be a personal issue item.
- before use ensure about the compatibility of items of equipment assembled into a fall arrest system. Periodically check connecting and adjusting of the equipment components to avoid accidental loosening or disconnecting of the components.
- it is forbidden to use combinations of items of equipment in which the safe function of any one item is affected by or interferes with the safe function of another.
- before each use of personal protective equipment it is obligatory to carry out a pre-use check of the equipment, to ensure that it is in a serviceable condition and operates correctly before it is used.
- during pre-use check it is necessary to inspect all elements of the equipment in respect of any damages, excessive wear, corrosion, abrasion, cutting or incorrect acting, especially take into consideration:
 - in full body harnesses and belts - buckles, adjusting elements, attaching points, webbings, seams, loops;
 - in energy absorbers - attaching loops, webbing, seams, casing, connectors;
 - in textile lanyards or lifelines or guidelines - rope, loops, thimbles, connectors, adjusting element, splices;
 - in steel lanyards or lifelines or guidelines - cable, wires, clips, ferrules, loops, thimbles, connectors, adjusting elements;
 - in retractable fall arresters - cable or webbing, retractor and brake proper acting, casing, energy absorber, connector;
 - in guided type fall arresters - body of the fall arrester, sliding function, locking gear acting, rivets and screws, connector, energy absorber;
 - in connectors - main body, rivets, gate, locking gear acting.
- after every 12 months of utilization, personal protective equipment must be withdrawn from use to carry out periodical detailed inspection. The periodic inspection must be carried out by a competent person for periodic inspection. The periodic inspection can be carried out also by the manufacturer or his authorized representative. In case of some types of the complex equipment e.g. some types of retractable fall arresters the annual inspection can be carried out only by the manufacturer or his authorized representative.
- regular periodic inspections are the essential for equipment maintenance and the safety of the users which depends upon the continued efficiency and durability of the equipment.
- during periodic inspection it is necessary to check the legibility of the equipment marking.
- it is essential for the safety of the user that if the product is re-sold outside the original country of destination the reseller shall provide instructions for use, for maintenance, for periodic examination and for repair in language of the country in which the product is to be used.

IT IS THE RESPONSIBILITY OF THE USER ORGANISATION TO PROVIDE THE IDENTITY CARD AND TO FILL IN THE DETAILS REQUIRED.
 THE IDENTITY CARD SHOULD BE FILLED IN BEFORE THE FIRST USE BY A COMPETENT PERSON, RESPONSIBLE IN THE USER ORGANIZATION FOR PROTECTIVE EQUIPMENT.
 ANY INFORMATION ABOUT THE EQUIPMENT LIKE PERIODIC INSPECTIONS, REPAIRS, REASONS OF EQUIPMENT'S WITHDRAWN FROM USE SHALL BE NOTED INTO THE IDENTITY CARD BY A COMPETENT PERSON.
 THE IDENTITY CARD SHOULD BE STORED DURING A WHOLE PERIOD OF EQUIPMENT UTILIZATION.
 DO NOT USE THE EQUIPMENT WITHOUT THE IDENTITY CARD.
 ALL RECORDS IN THE IDENTITY CARD CAN BE FILLED IN ONLY BY A COMPETENT PERSON.

IDENTITY CARD

GUIDED-TYPE FALL ARRESTER ON FLEXIBLE ANCHORAGE LINE

WORKING ROPE ø14 mm polyamide

REF. NUMBER		LENGTH	
-------------	--	--------	--

SERIAL NUMBER		DATE OF MANUF.	
---------------	--	----------------	--

USER NAME	

	DATE OF PUTTING INTO OPERATION
--	--------------------------------

DATE OF PURCHASE	
------------------	--

PERIODIC EXAMINATION AND REPAIR HISTORY

	DATE	REASON FOR ENTRY PERIODIC EXAMINATION OR REPAIR	DEFECTS NOTED, REPAIRS CARRIED OUT AND OTHER REVELANT INFORMATIONS	NAME AND SIGNATURE OF COMPETENT PERSON	PERIODIC EXAMINATION NEXT DUE DATE
1					
2					
3					
4					



PDS International Pte Ltd ; 10 Pandan Crescent, #05-03/04 (L12) ; UE Tech Park ; Singapore 128466
 Tel : +65 6776 6200 ; Fax : +65 6778 2400

IT IS THE RESPONSIBILITY OF THE USER ORGANISATION TO PROVIDE THE IDENTITY CARD AND TO FILL IN THE DETAILS REQUIRED.
 THE IDENTITY CARD SHOULD BE FILLED IN BEFORE THE FIRST USE BY A COMPETENT PERSON, RESPONSIBLE IN THE USER ORGANIZATION FOR PROTECTIVE EQUIPMENT.
 ANY INFORMATION ABOUT THE EQUIPMENT LIKE PERIODIC INSPECTIONS, REPAIRS, REASONS OF EQUIPMENT'S WITHDRAWN FROM USE SHALL BE NOTED INTO THE IDENTITY CARD BY A COMPETENT PERSON.
 THE IDENTITY CARD SHOULD BE STORED DURING A WHOLE PERIOD OF EQUIPMENT UTILIZATION.
 DO NOT USE THE EQUIPMENT WITHOUT THE IDENTITY CARD.
 ALL RECORDS IN THE IDENTITY CARD CAN BE FILLED IN ONLY BY A COMPETENT PERSON.

IDENTITY CARD

GUIDED-TYPE FALL ARRESTER ON FLEXIBLE ANCHORAGE LINE

WORKING ROPE ø14 mm polyamide

REF. NUMBER		LENGTH	
-------------	--	--------	--

SERIAL NUMBER		DATE OF MANUF.	
---------------	--	----------------	--

USER NAME	

	DATE OF PUTTING INTO OPERATION
--	--------------------------------

DATE OF PURCHASE	
------------------	--

PERIODIC EXAMINATION AND REPAIR HISTORY

	DATE	REASON FOR ENTRY PERIODIC EXAMINATION OR REPAIR	DEFECTS NOTED, REPAIRS CARRIED OUT AND OTHER REVELANT INFORMATIONS	NAME AND SIGNATURE OF COMPETENT PERSON	PERIODIC EXAMINATION NEXT DUE DATE
1					
2					
3					
4					



PDS International Pte Ltd ; 10 Pandan Crescent, #05-03/04 (L12) ; UE Tech Park ; Singapore 128466
 Tel : +65 6776 6200 ; Fax : +65 6778 2400

IT IS THE RESPONSIBILITY OF THE USER ORGANISATION TO PROVIDE THE IDENTITY CARD AND TO FILL IN THE DETAILS REQUIRED.
 THE IDENTITY CARD SHOULD BE FILLED IN BEFORE THE FIRST USE BY A COMPETENT PERSON, RESPONSIBLE IN THE USER ORGANIZATION FOR PROTECTIVE EQUIPMENT.
 ANY INFORMATION ABOUT THE EQUIPMENT LIKE PERIODIC INSPECTIONS, REPAIRS, REASONS OF EQUIPMENTS WITHDRAWN FROM USE SHALL BE NOTED INTO THE IDENTITY CARD BY A COMPETENT PERSON.
 THE IDENTITY CARD SHOULD BE STORED DURING A WHOLE PERIOD OF EQUIPMENT UTILIZATION.
 DO NOT USE THE EQUIPMENT WITHOUT THE IDENTITY CARD.
 ALL RECORDS IN THE IDENTITY CARD CAN BE FILLED IN ONLY BY A COMPETENT PERSON.

IDENTITY CARD

GUIDED-TYPE FALL ARRESTER ON FLEXIBLE ANCHORAGE LINE

ROPE GRAB WSFAC010

SERIAL NUMBER		DATE OF MANUF.	
---------------	--	----------------	--

USER NAME	

	DATE OF PUTTING INTO OPERATION
--	--------------------------------

DATE OF PURCHASE	
------------------	--

PERIODIC EXAMINATION AND REPAIR HISTORY					
	DATE	REASON FOR ENTRY PERIODIC EXAMINATION OR REPAIR	DEFECTS NOTED, REPAIRS CARRIED OUT AND OTHER REVELANT INFORMATIONS	NAME AND SIGNATURE OF COMPETENT PERSON	PERIODIC EXAMINATION NEXT DUE DATE
1					
2					
3					
4					

IT IS THE RESPONSIBILITY OF THE USER ORGANISATION TO PROVIDE THE IDENTITY CARD AND TO FILL IN THE DETAILS REQUIRED.
 THE IDENTITY CARD SHOULD BE FILLED IN BEFORE THE FIRST USE BY A COMPETENT PERSON, RESPONSIBLE IN THE USER ORGANIZATION FOR PROTECTIVE EQUIPMENT.
 ANY INFORMATION ABOUT THE EQUIPMENT LIKE PERIODIC INSPECTIONS, REPAIRS, REASONS OF EQUIPMENTS WITHDRAWN FROM USE SHALL BE NOTED INTO THE IDENTITY CARD BY A COMPETENT PERSON.
 THE IDENTITY CARD SHOULD BE STORED DURING A WHOLE PERIOD OF EQUIPMENT UTILIZATION.
 DO NOT USE THE EQUIPMENT WITHOUT THE IDENTITY CARD.
 ALL RECORDS IN THE IDENTITY CARD CAN BE FILLED IN ONLY BY A COMPETENT PERSON.

IDENTITY CARD

GUIDED-TYPE FALL ARRESTER ON FLEXIBLE ANCHORAGE LINE

ROPE GRAB WSFAC010

SERIAL NUMBER		DATE OF MANUF.	
---------------	--	----------------	--

USER NAME	

	DATE OF PUTTING INTO OPERATION
--	--------------------------------

DATE OF PURCHASE	
------------------	--

PERIODIC EXAMINATION AND REPAIR HISTORY					
	DATE	REASON FOR ENTRY PERIODIC EXAMINATION OR REPAIR	DEFECTS NOTED, REPAIRS CARRIED OUT AND OTHER REVELANT INFORMATIONS	NAME AND SIGNATURE OF COMPETENT PERSON	PERIODIC EXAMINATION NEXT DUE DATE
1					
2					
3					
4					